

TRIWPT Wireless Power Transfer Lab Circuit Board Construction

To create the necessary circuit boards for each pair of lab apparatus, you will need the following items on the Bill of Materials:

TRIWPT PCB BOM

Part #	Qty	Description	Source	Price
AT-201N	2	Tuning Cap 0-200pF	Ebay	\$15.00
ED2561-ND	6	Two Pin Terminal Block	Digikey	\$0.32
490-4168-ND	2	100pF Radial Capacitor 5%	Digikey	\$0.25
445-2606-ND	2	470pF Capacitor 5%	Digikey	\$0.28
a14041800ux1143	2	4cm X 6cm Protoboard	Amazon	\$15.00

You will also need a soldering iron, solder, and a hot glue gun.

Instructions

1. Follow the Hyperlinks and order the necessary components

The Ebay hyperlink may no longer work. If this is the case, please order an equivalent 0-200pF tuning capacitor. Several of the items above are sold in multi-pack quantities with enough to construct several TRIWPT apparatus.

2. Unpack terminal blocks and connect to each other into two groups of three for each board (Fig 1)

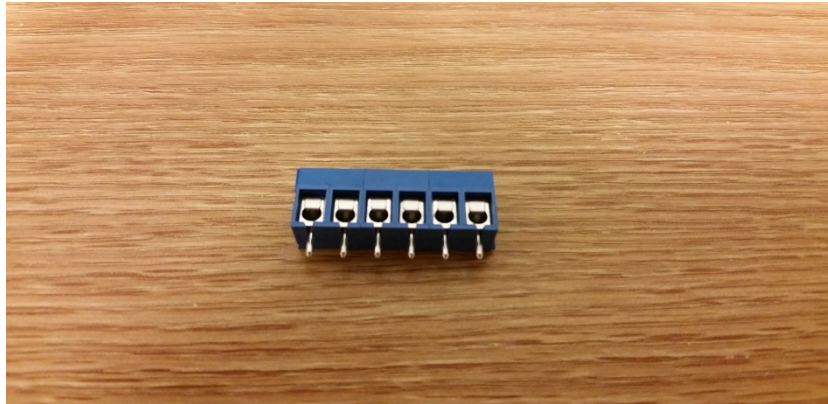

Figure 1: Terminal blocks in grouping of three

3. Solder jumper wire and protoboard connection leads to tuning capacitor as shown in Fig 2:

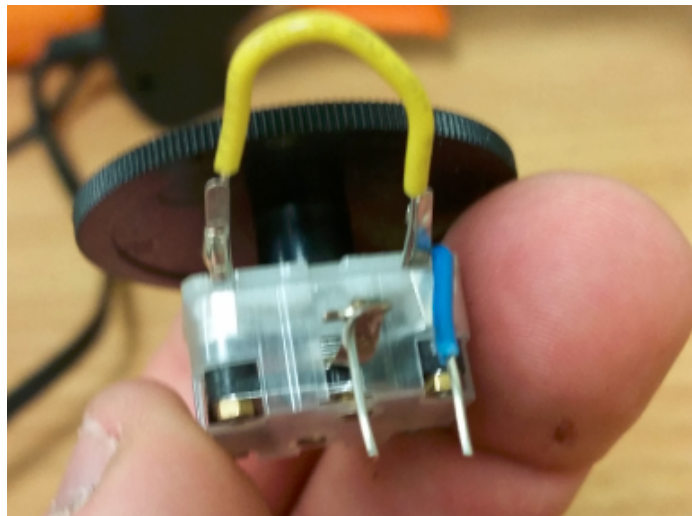

Figure 2: Tuning capacitor wiring connections

4. Place Tuning capacitor body on top of one corner of protoboard with leads facing towards center of board. Stick leads through protoboard holes with 1 hole separating the two leads. Place one 100pF and one 470 pF capacitor in line with the tuning cap leads. After completing this step, the board should look like shown in Fig. 3:

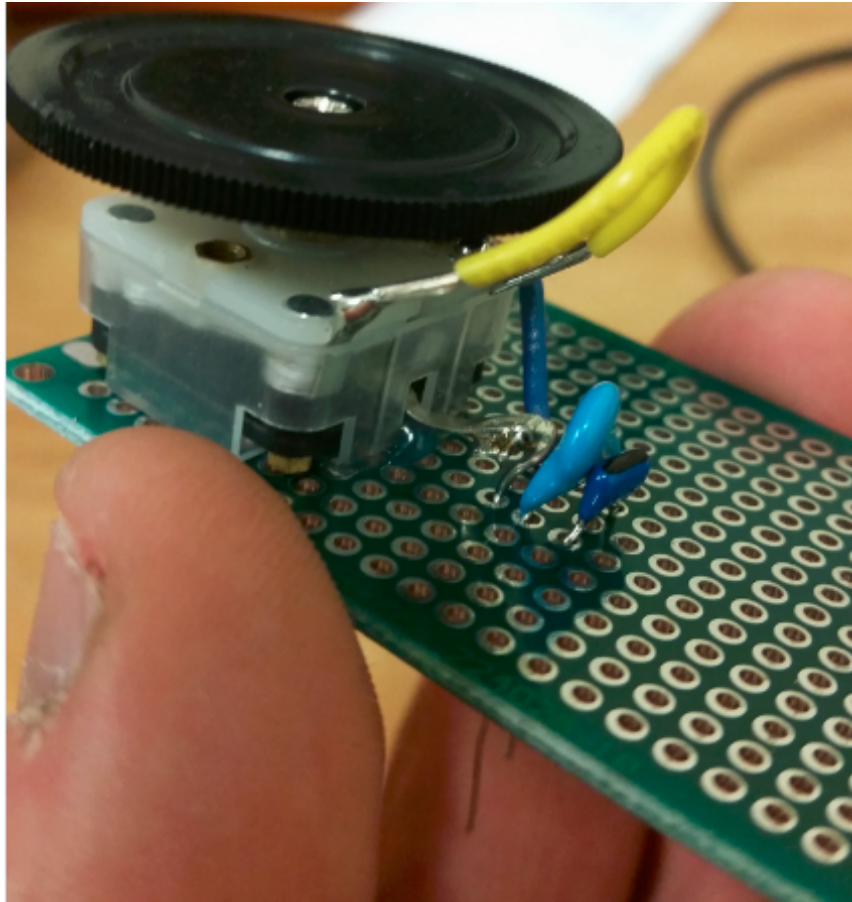

Figure 3: Capacitor installation arrangement on protoboard

5. Solder the leads of the capacitors together on each side (they are to be connected in parallel):

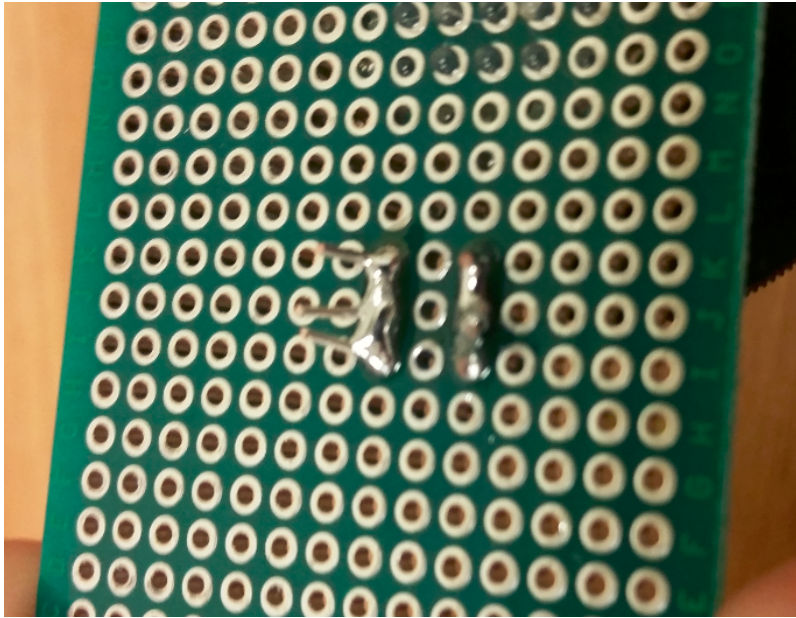

Figure 4: Parallel capacitor connections

6. Place one of the terminal assembled terminal blocks adjacent to the capacitor bank as shown (Figs 5&6):

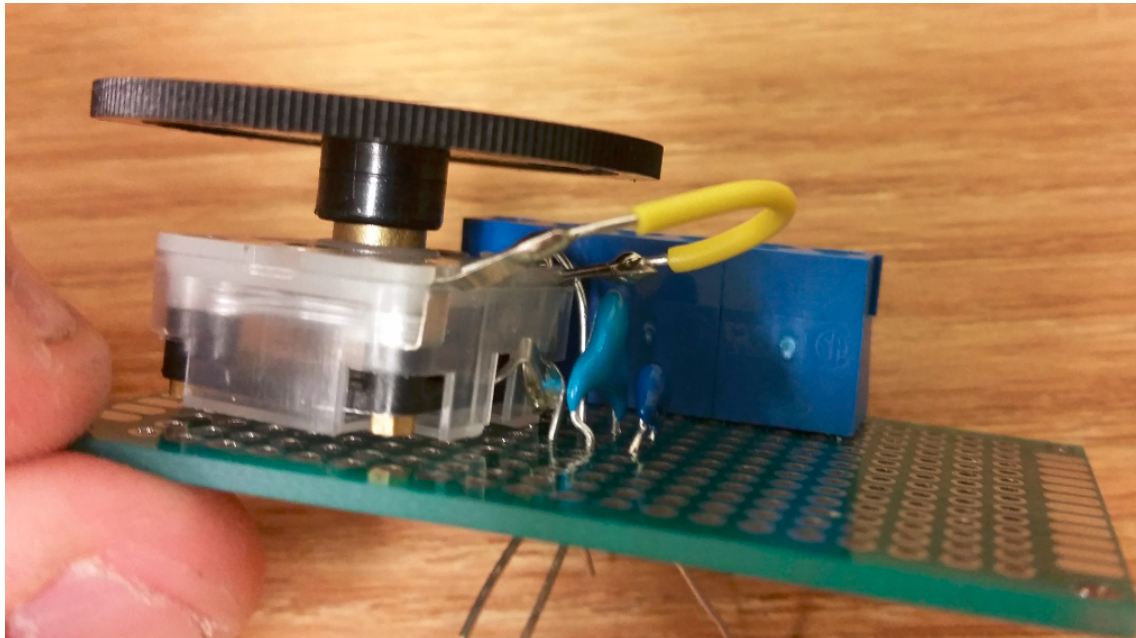

Figure 5: Installation of capacitors and one terminal block

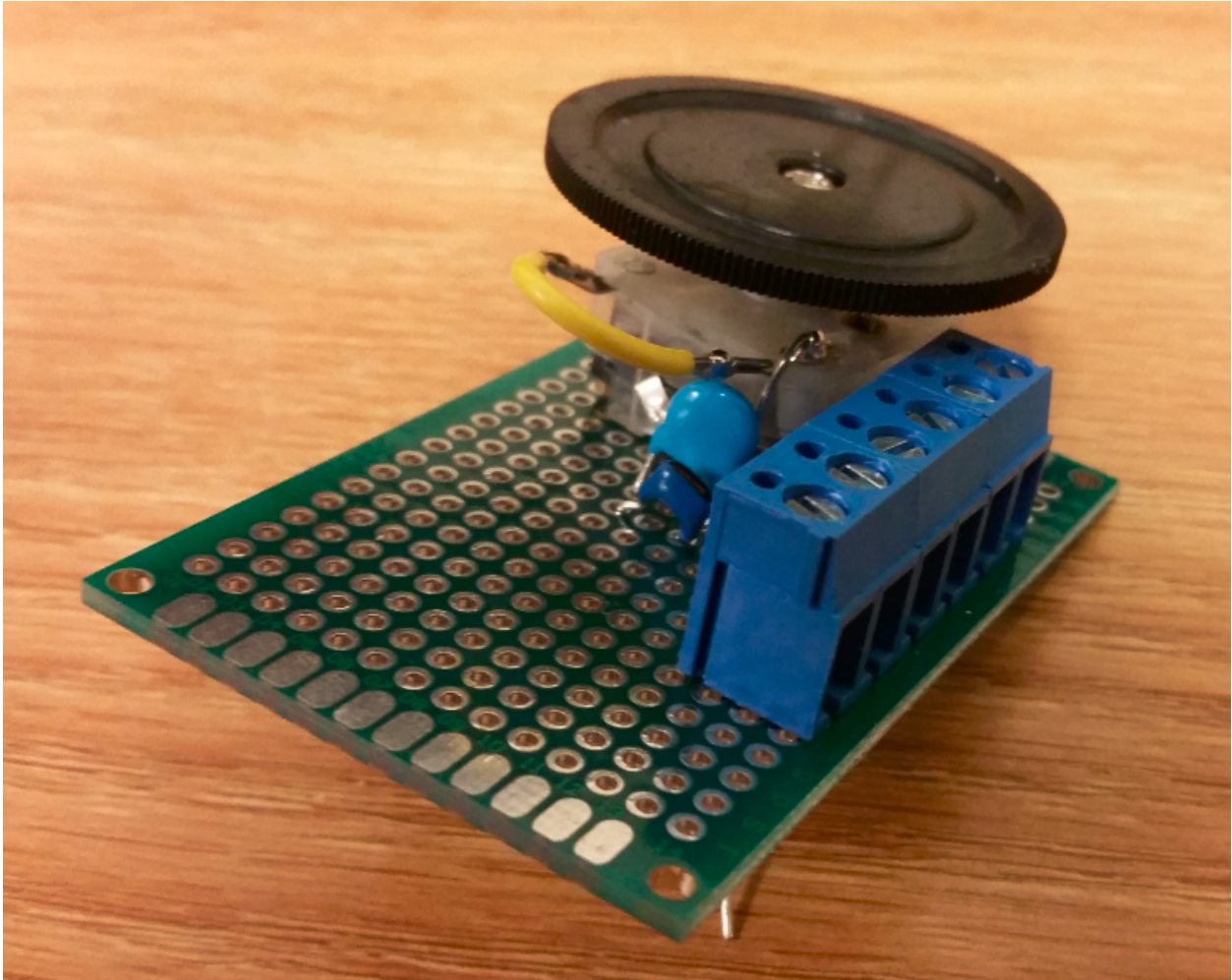

Figure 6: Capacitor and terminal block installation detail on protoboard

7. Install second terminal block assembly onto protoboard as shown in Fig 7:

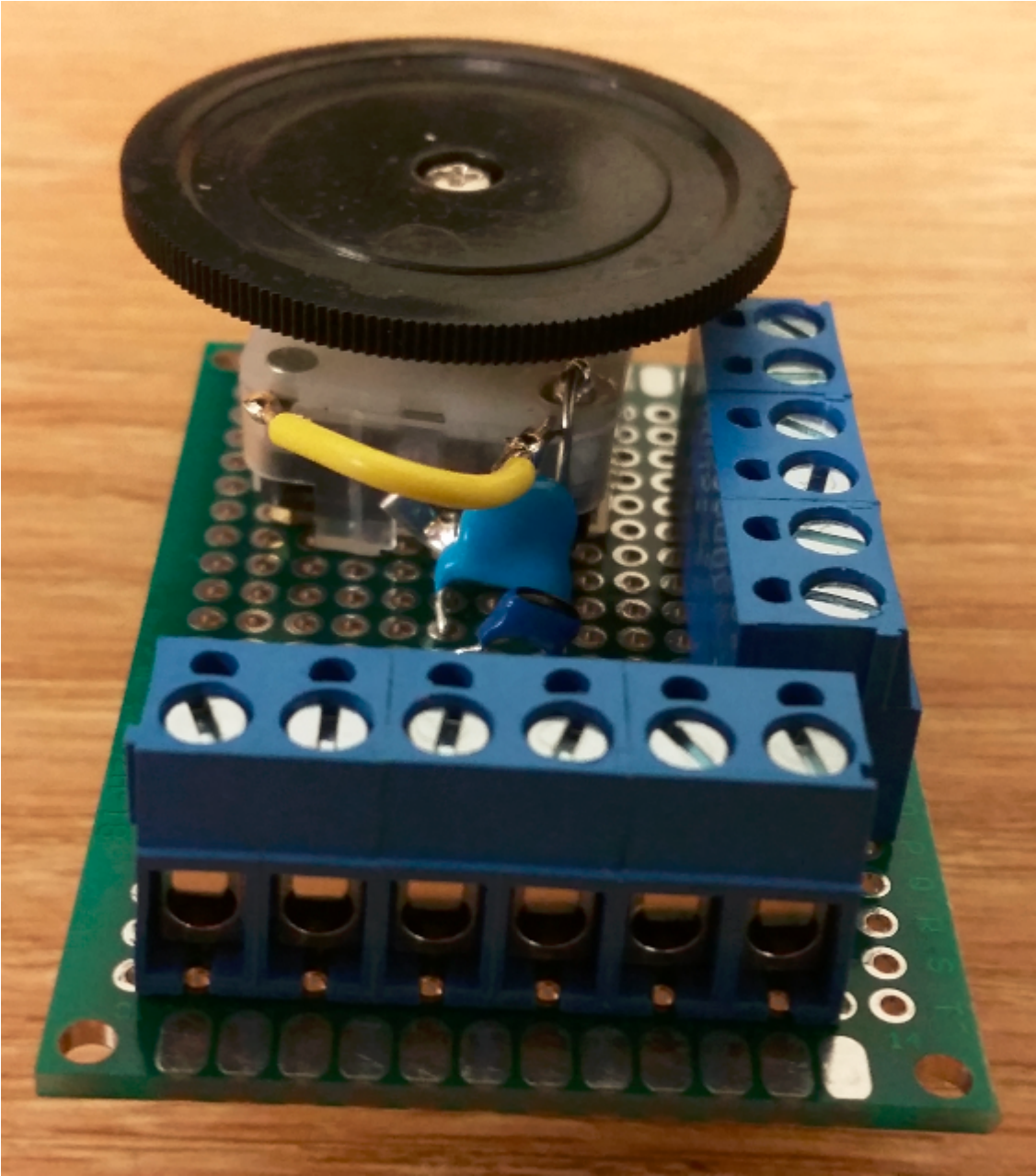

Figure 7: Installation detail of all components on protoboard

8. Using a hot glue gun, glue the bottom of the tuning capacitor to the top of the protoboard (Fig 8)

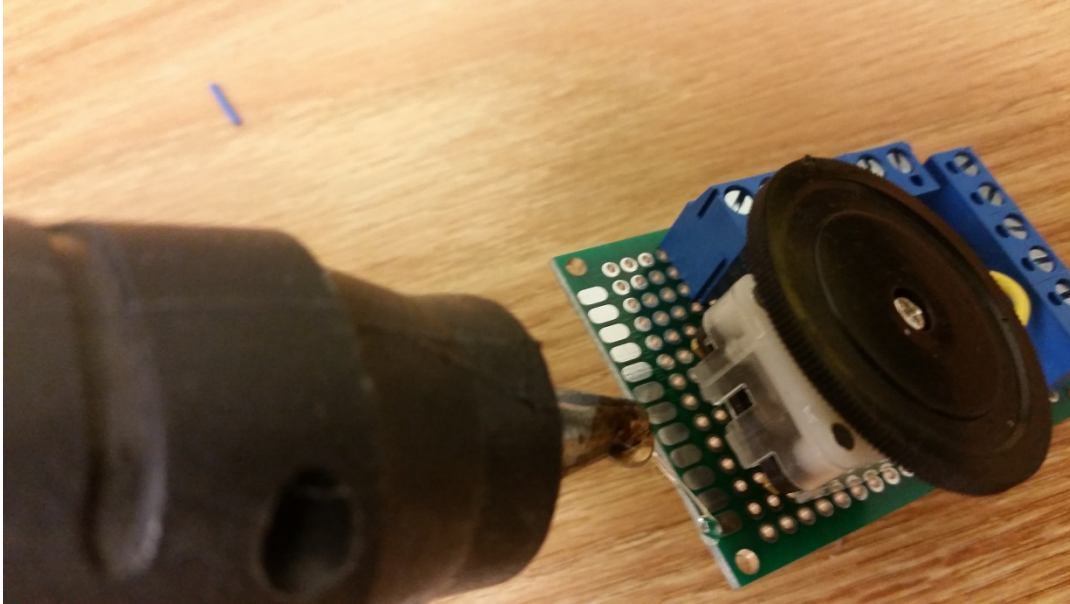

Figure 8: Gluing tuning capacitor to board using hot glue gun

9. Solder the board as shown below in Fig 9. As you can see, the three terminals of the “first installed terminal block” are connected in series to the capacitor bank. These terminals will connect to the inductor loop and source/loads. The terminals of the “second installed terminal block” are all connected in parallel. These terminals will connect to a separate inductor loop and source/loads in the TRIWPT Four-Loop configuration. See Figs 9 through 14 for details and schematics.

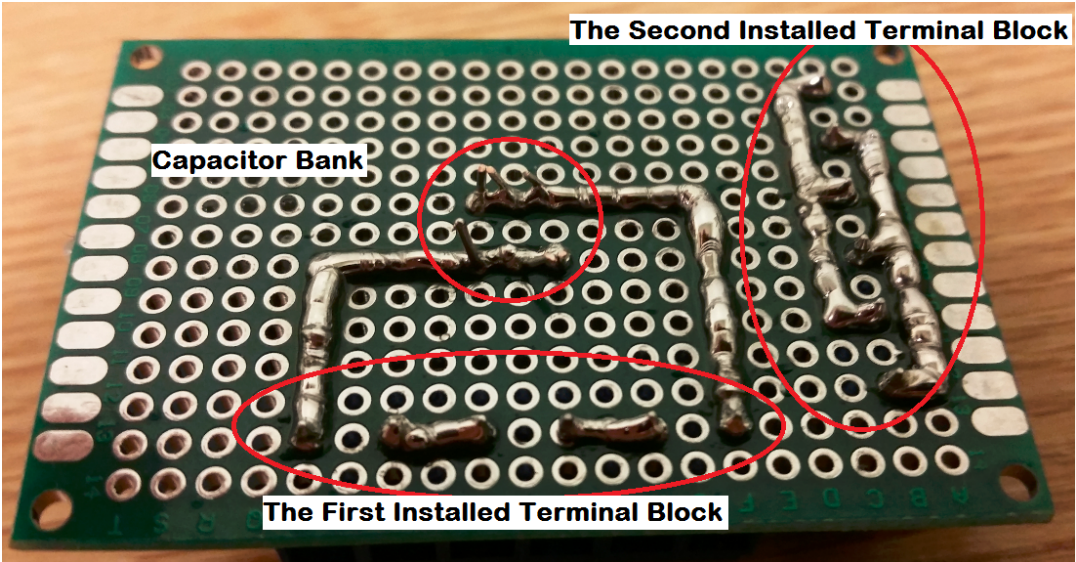

Figure 9: Circuit board solder pattern

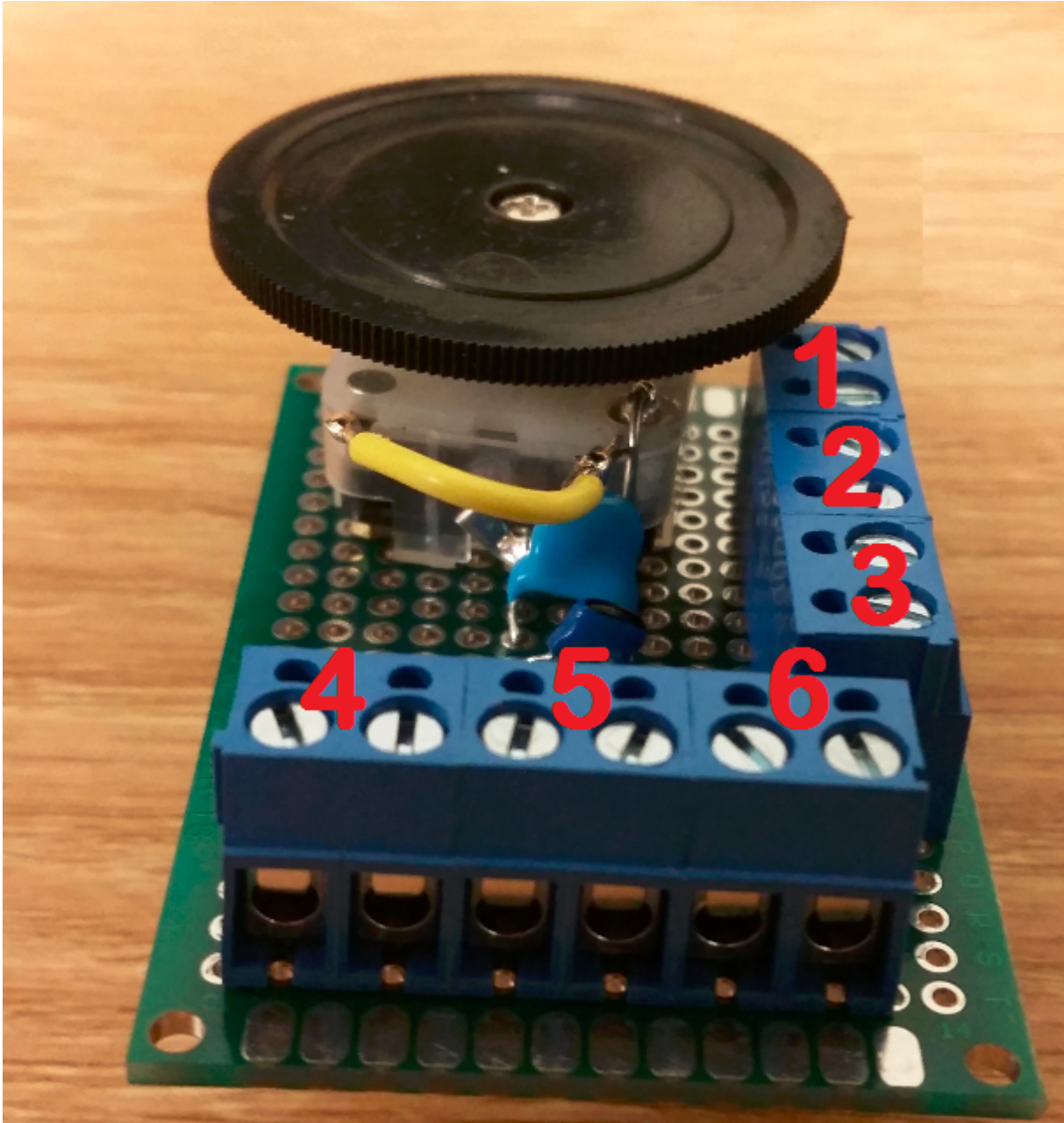
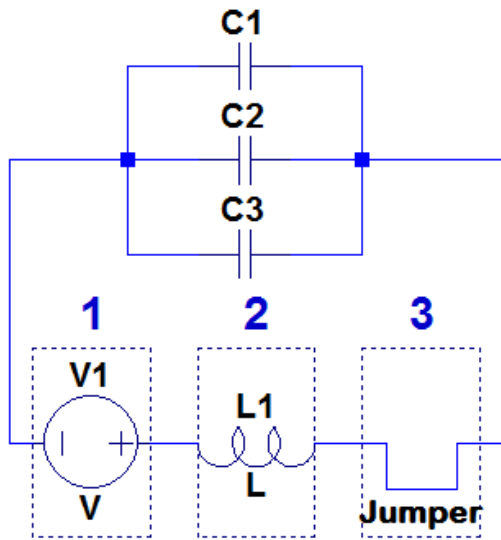
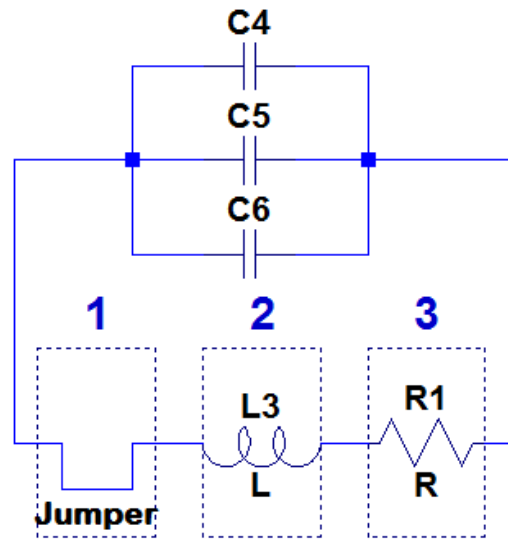

Figure 10: Terminal block definitions for TRIWPT system circuit board

TWO-LOOP OPERATION



Sender Apparatus Connections



Receiver Apparatus Connections

Figure 11: Connection Schematic, Two-Loop Configuration

FOUR-LOOP OPERATION SENDER APPARATUS

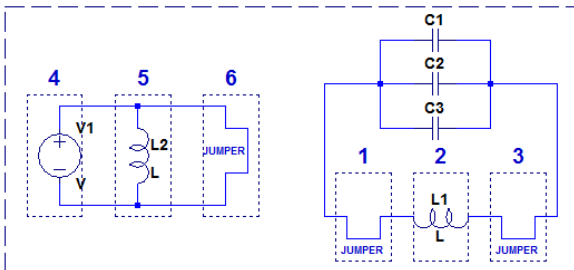

FOUR-LOOP OPERATION RECEIVER APPARATUS

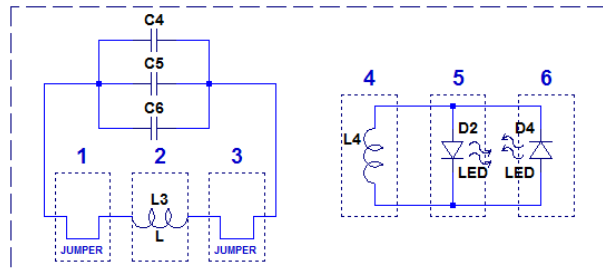

Figure 12: Connection Schematic, Four-Loop Configuration (Overall)

FOUR-LOOP OPERATION SENDER APPARATUS

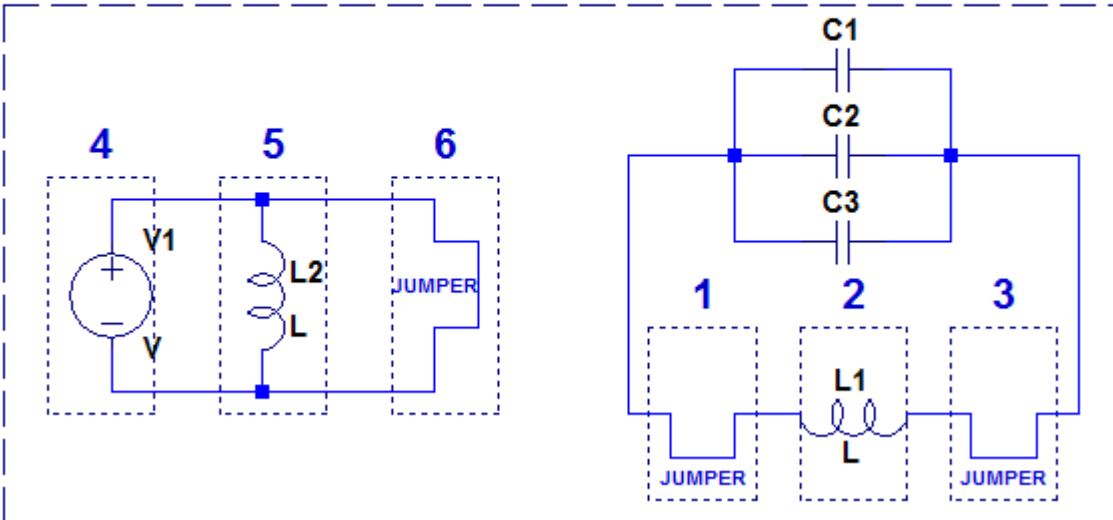

Figure 13: Connection Schematic, Four-Loop Sender Detail

FOUR-LOOP OPERATION RECEIVER APPARATUS

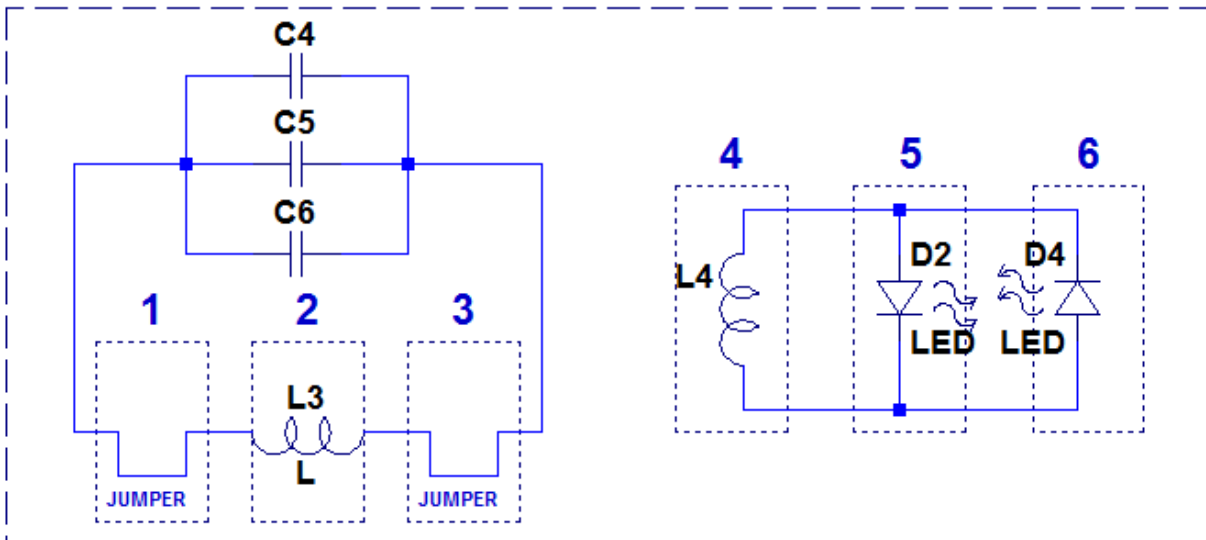

Figure 14: Connection Schematic, Four-Loop Receiver Detail

10. Next, use the hot glue gun to secure the circuit boards to your inductor rings (jigs), similarly to Fig 15.



Figure 15: Circuit boards glued to inductor rings (jigs)

11. 3D print the jig stand holders using the .stl file included in the lab materials. Then slide the holder onto the jig stands, and you're all done! See Fig. 16.

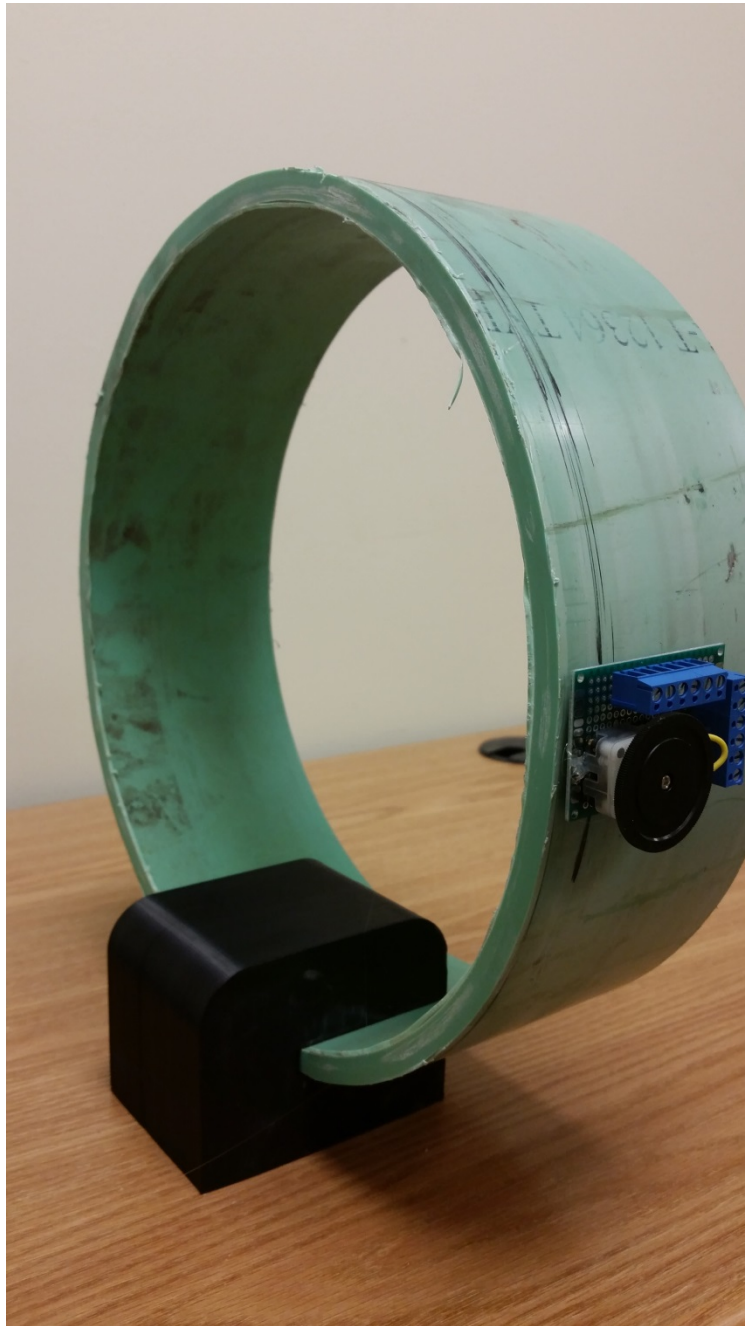

Figure 16: Inductor jig stand with 3D printed holder installed.